

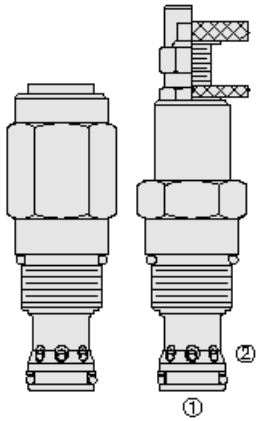

Overview



Description

RV52-26X is a screw in, cartridge style, pilot operated (two stage), spool type relief valve, intended for use as a pressure limiting device in demanding hydraulic circuits which require fast response and low hysteresis.

Operation

The RV52-26X blocks flow from port 1 to port 2 until sufficient pressure is present at port 1 to force the pilot relief off its seat, allowing the main stage to shift, opening port 1 to port 2.

note: this valve cannot be used in cross-over relief applications.

Features

- Adjustments cannot be backed out of the valve.
- Adjustment options A, B and C: positive stops prevent springs from going solid.
- Hardened spool and cage for long life.
- Rapid, smooth response to pressure surges.
- Cost-effective cavity.

Symbol

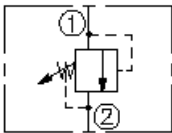

Ratings

Pressure Ratings

Pressure rating	344.7 bar (5000 psi)	- Note: Port 1
	103.4 bar (1500 psi)	- Note: Port 2
Proof pressure	689.5 bar (10000 psi)	
Burst pressure	1379.0 bar (20000 psi)	
Crack pressure defined	Pressure evident at 7.6 lpm (2 gpm)	
Relief pressure range	41.4 to 345 bar (600 to 5000 psi)	- Note: From zero to maximum control current

Flow Ratings

Flow rating	189.3 lpm (50 gpm)	- Note: At max pressure
-------------	--------------------	--------------------------------

Temperature Ratings

Operating fluid temperature	-54 to 107 °C (-65 to 225 °F)	- Note: With polyurethane seals
Storage temperature	-40 to 70 °C (-40 to 160 °F)	
Ambient temperature	-40 to 70 °C (-40 to 160 °F)	

Other Ratings

Corrosion protection	960 hr salt spray per ASTM b117 (grv52-26x)
----------------------	---

Operating Parameters

Fluids	Mineral based or synthetic with lubricating properties
Fluid viscosity range	7.4 to 420 cSt
Maximum operating contamination level	18/16/13 per ISO 4406

Properties

Unit weight	0.35 kg (0.78 lb)	- Note: "a"
	0.38 kg (0.83 lb)	- Note: "b"
	0.40 kg (0.88 lb)	- Note: "c l"
	0.40 kg (0.89 lb)	- Note: "f h"
Internal wetted surface area	209 cm ² (32.4 in ²)	
	221 cm ² (34.3 in ²)	



Performance

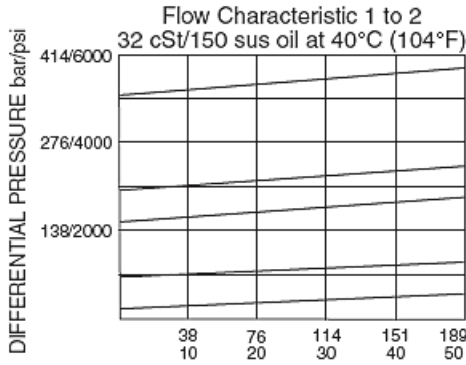

Dimensions

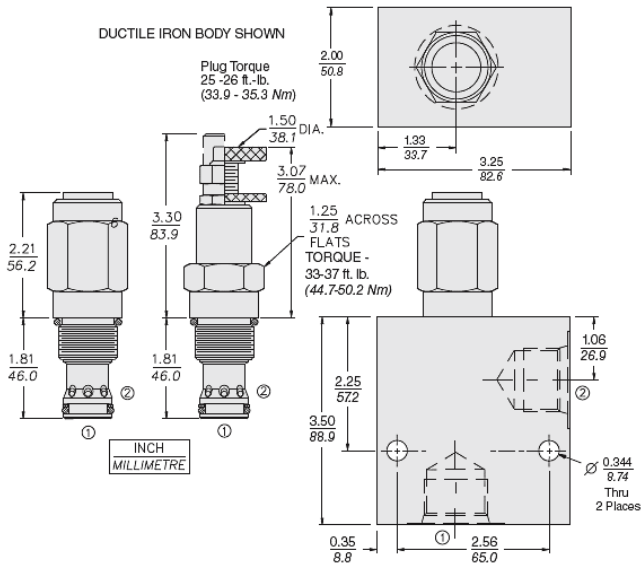

Installation Specifications

Cavity	VC12-2
Cartridge installation torque	44.7 to 50.2 N-m (33 to 37 ft-lb)
H style plug torque	33.9 to 35.3 N-m (25 to 26 ft-lb)
Orientation restriction	None

Accessories

Seal kit	SK12-2P-B
----------	-----------

Order Code

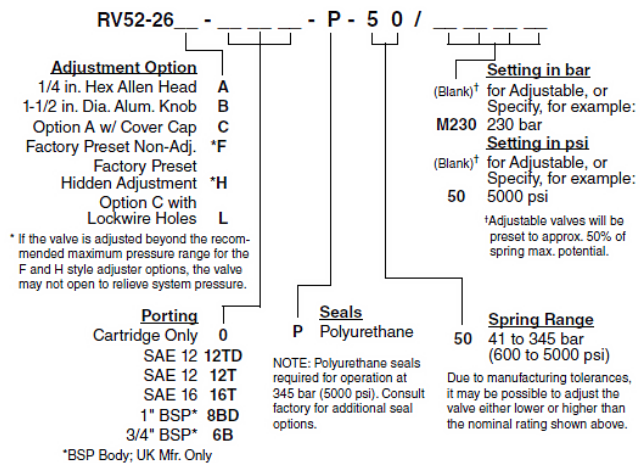



Model Options

RV52-26F-H-J-R/S

F Adjustment Option

CODE	DESCRIPTION
A	1/4" Hex Allen Head
B	1-1/2" Diameter Aluminum Knob with Aluminum Lock Knob
C	1/4" Hex Allen Head with Cover Cap
F	Factory Preset Non-Adjustable
H	Factory Preset Hidden Adjustment
L	1/4" Hex Allen Head with Cover Cap and Lockwire Holes

H Line Body

CODE	DESCRIPTION
0	No Body
10T	Aluminum SAE 10
12T	Aluminum SAE 12
16T	Aluminum SAE 16
12TD	Ductile Iron SAE 12
16TD	Ductile Iron SAE 16
8B	Aluminum BSPP 1" (8)
8BD	Ductile Iron BSPP 1" (8)

J Seal

CODE	DESCRIPTION
N	Buna-N
V	Fluorocarbon
P	Polyurethane

R Spring

CODE	DESCRIPTION
50	83 to 344.7 bar (1200 to 5000 psi) Spring Range

S Setting

CODE	DESCRIPTION
MXXX	Spring Setting in XXX bar
XX	Spring Setting in XX psi (x 100)