

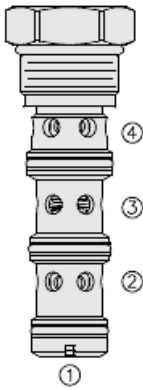

Overview



Description

The FD56-45 is a screw-in cartridge, spool type flow divider/combiner valve.

Operation

The cartridge valve provides pressure compensated proportional division of inlet flow or combining of two return flows regardless of system operating pressure conditions. The valve provides synchronizing flow in dividing and combining modes.

Features

- Hardened parts for long life.
- Quiet, modulated response.
- Wide operating flow range.
- Synchronizing in dividing and combining modes.
- Floating cage "high installation torque.
- Industry common cavity.

Symbol

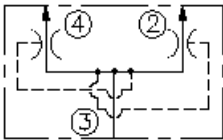

Ratings

Pressure Ratings

Pressure rating	345 bar (5000 psi) 420 bar (6090 psi)	- Note: 10% duty cycle
Pressure drop	24 bar (300 psi)	- Note: At maximum inlet flow

Flow Ratings

Inlet flow rating	25 to 98 lpm (6.5 to 26.0 gpm)	- Note: Model code 44
	32 to 128 lpm (8.5 to 34.0 gpm)	- Note: Model code 66
	57 to 167 lpm (15.0 to 44.0 gpm)	- Note: Model code 88
	68 to 197 lpm (18.0 to 52.0 gpm)	- Note: Model code 99
Synchronizing flow	Approximately 10% of maximum inlet flow	
Flow accuracy	10 %	- Note: Of inlet flow for -22, -33, -44, -55 and -66 models
	15 %	- Note: Of inlet flow for -88 and -99 models

Temperature Ratings

Operating fluid temperature	-40 to 100 °C (-40 to 212 °F)	- Note: With buna N seals
	-26 to 204 °C (-15 to 400 °F)	- Note: With fluorocarbon seals
	-54 to 107 °C (-65 to 225 °F)	- Note: With polyurethane seals
	-54 to 107 °C (-65 to 225 °F)	- Note: With urethane seals
Storage temperature	-40 to 70 °C (-40 to 160 °F)	
Ambient temperature	-40 to 90 °C (-40 to 194 °F)	

Operating Parameters

Fluids	Mineral based or synthetic hydraulic fluid with lubricating properties
Fluid viscosity range	7.4 to 420 cSt
Maximum operating contamination level	18/16/13 per ISO 4406

Properties

Unit weight	0.38 kg (0.83 lb)
Internal wetted surface area	403 cm ² (62.4 in ²)



Performance

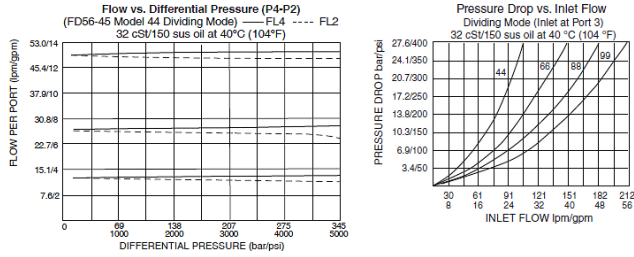

Dimensions

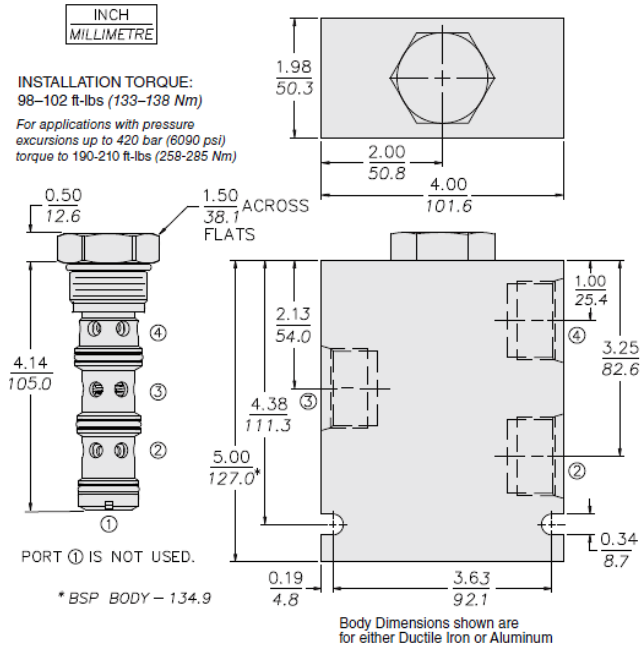

Installation Specifications

Cavity	VC16-4
Cartridge installation torque	HVC16-4 for applications with pressure excursions up to 420 bar (6090 psi) 133 to 138 N-m (98 to 102 ft-lb) 258 to 285 N-m (190 to 210 ft-lb) - Note: For applications with pressure excursions up to 6090 psi [420 bar]
Orientation restriction	None

Accessories

Seal kit	SK16-4X-MMM polyurethane - Note: X = seal option; buna n, fluorocarbon, SK16-4U-OOO urethane - Note: Urethane
----------	--



Order Code

FD56-45 -



- Ported Bodies**
- Cartridge Only 0
 - SAE 12 (all ports) 12T
 - SAE 16 (all ports) 16T
 - SAE 16 (all ports) 16TD
 - 1 in. BSP* (all ports) 8B

*BSP Body; U.K. Mfr. Only

Dividing/Combining Ratio

- 44 50:50 rated @ 25-98 lpm (6.5-26 gpm) input
- 66 50:50 rated @ 32-128 lpm (8.5-34 gpm) input
- 88 50:50 rated @ 57-167 lpm (15-44 gpm) input
- 99 50:50 rated @ 68-197 lpm (18-52 gpm) input

Seals

- N Buna N (Std.)
- V Fluorocarbon
- P Polyurethane (Required for operation over 240 bar/3500 psi)
- U Urethane (Required for applications with pressure excursions up to 420 bar/6090 psi)

Model Options

FD56-45-H-J-N

H Line Body

CODE	DESCRIPTION
0	No Body
16T	Aluminum SAE 16
12TD	Ductile Iron SAE 12
16TD	Ductile Iron SAE 16

J Seal

CODE	DESCRIPTION
N	Buna-N
V	Fluorocarbon
P	Polyurethane

N Flow Dividing/Combining

CODE	DESCRIPTION
11	Not listed in outline
22	Not listed in outline
33	Not listed in outline
44	50/50 Rated at 25.0-98.0 lpm (6.5-26.0 gpm)
55	Not listed in outline
66	50/50 Rated at 32.0-34.0 lpm (8.5-34.0 gpm)
77	Not listed in outline
88	50/50 Rated at 57.0-167.0 lpm (15.0-44.0 gpm)
99	50/50 Rated at 68.0-197.0 lpm (18.0-52.0 gpm)