

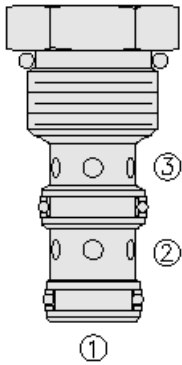

Overview



Description

The LS50-30 is a load shuttle, screw-in, cartridge style, hydraulic check valve, for use in blocking circuits where a priority of flow/direction is given to a higher pressure circuit over a lower one.

Operation

The LS50-30 will allow flow from the higher pressure of port 1 or port 3 to port 2.

Features

- Rapid response to load direction changes.
- Industry-common cavity.

Symbol

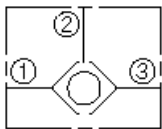

Ratings

Pressure Ratings

Pressure rating 345 bar (5000 psi)

Flow Ratings

Flow rating 30.3 lpm (8 gpm)
Maximum internal leakage 5 drops/min - **Note:** At 345 bar (5000 psi)

Temperature Ratings

Operating fluid temperature	-26 to 204 °C (-15 to 400 °F)	- Note: With fluorocarbon seals
	-54 to 107 °C (-65 to 225 °F)	- Note: With polyurethane seals
	-54 to 107 °C (-65 to 225 °F)	- Note: With urethane seals
Storage temperature	-40 to 70 °C (-40 to 160 °F)	
Ambient temperature	-40 to 90 °C (-40 to 194 °F)	

Other Ratings

Corrosion protection 960 hr salt spray per ASTM b117 (gls50-30)

Operating Parameters

Fluids	Mineral based or synthetic hydraulic fluid with lubricating properties
Fluid viscosity range	7.4 to 420 cSt
Maximum operating contamination level	20/18/14 per ISO 4406

Properties

Unit weight	0.09 kg (0.2 lb)
Internal wetted surface area	89 cm ² (13.8 in ²)



Performance

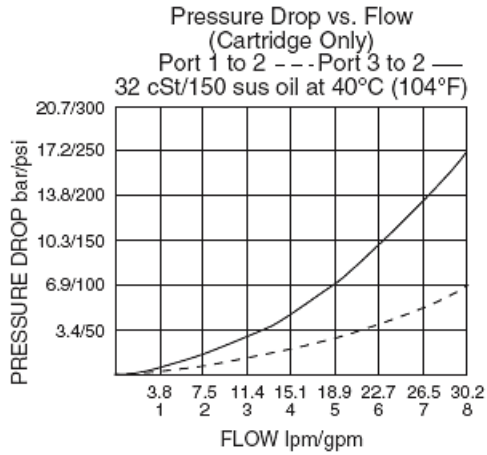

Dimensions

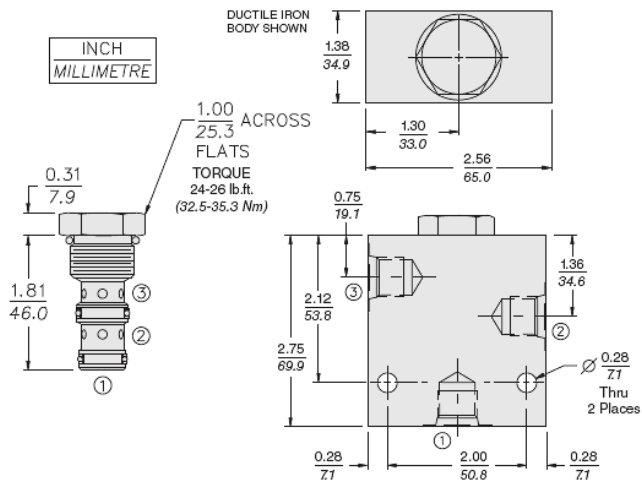

Installation Specifications

Cavity	VC10-3
Cartridge installation torque	44.7 to 50.2 N-m (33 to 37 ft-lb)
Maximum allowable torque	67.8 N-m (50 ft-lb)
Orientation restriction	None

Accessories

Seal kit	SK10-3HV-MM - Note: Fluorocarbon
	SK10-3P-MM - Note: Polyurethane
	SK10-3U-OO - Note: Urethane
Housings	



Order Code

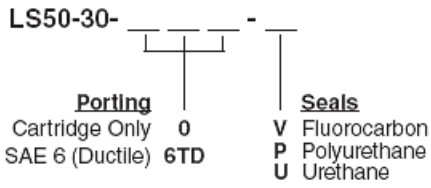

POSITION	CODE	DESCRIPTION
		LS50-30-H-J
H		Line Body
H	0	No Body
H	6T	Aluminum SAE 6
H	8T	Aluminum SAE 8
H	6TD	Ductile Iron SAE 6
H	8TD	Ductile Iron SAE 8
H	3B	Aluminum BSPP 3/8" (3)
H	3BD	Ductile Iron BSPP 3/8" (3)
J		Seal
J	N	Buna-N
J	V	Fluorocarbon
J	P	Polyurethane