

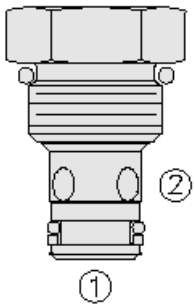

Overview



Description

The CV08-20 is a screw-in, cartridge style, hydraulic check valve for use as a blocking or load-holding device.

Operation

The cartridge valve allows flow from port 1 to 2, while normally blocking flow in the opposite direction. The cartridge valve has a fully guided check which is spring biased closed until sufficient pressure is applied at port 1 to open to port 2.

Features

- Hardened seat for long life and low leakage.
- Optional bias springs for back-pressure application flexibility.
- Fully guided check assembly.
- Compact size.
- Fast closing and seating.

Symbol

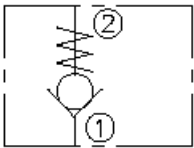

Ratings

Pressure Ratings

Pressure rating	241 bar (3500 psi)
Proof pressure	350 bar (5075 psi)
Burst pressure	1034 bar (15000 psi)

Flow Ratings

Flow rating	See graph
Maximum internal leakage	0.10 ml/min (2 drops/min) - Note: At 241 bar (3500 psi)

Temperature Ratings

Operating fluid temperature	-40 to 100 °C (-40 to 212 °F)	- Note: With buna N seals
	-26 to 204 °C (-15 to 400 °F)	- Note: With fluorocarbon seals
	-54 to 107 °C (-65 to 225 °F) seals	- Note: With urethane and polyurethane
Storage temperature	-40 to 70 °C (-40 to 160 °F)	
Ambient temperature	-40 to 90 °C (-40 to 194 °F)	

Other Ratings

Corrosion protection	960 hour salt spray per ASTM b117	- Note: GCV08-20 only
----------------------	-----------------------------------	------------------------------

Operating Parameters

Fluids	Mineral based or synthetic hydraulic fluid with lubricating properties
Fluid viscosity range	7.4 to 420 cSt
Maximum operating contamination level	20/18/14 per ISO 4406

Properties

Unit weight	0.05 kg (0.12 lb)
Internal wetted surface area	60 cm ² (9.3 in ²)



Performance

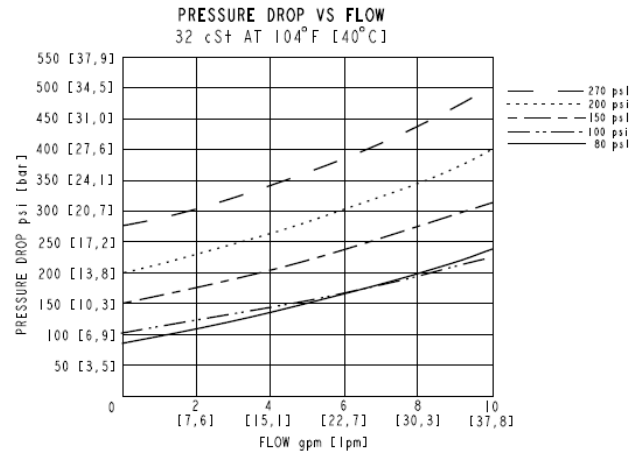
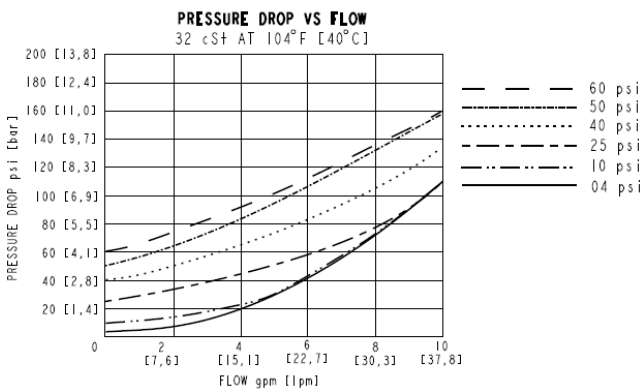
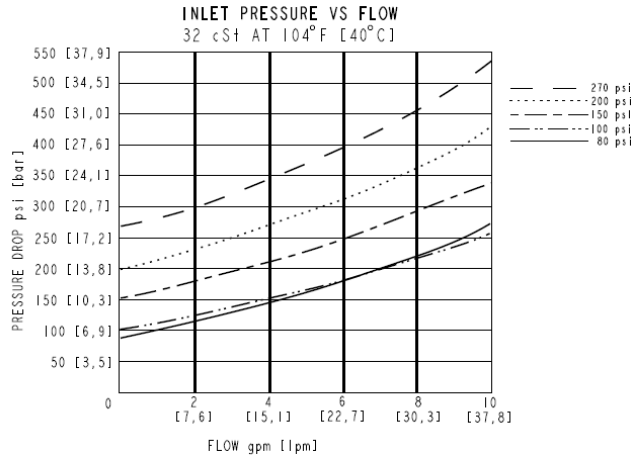
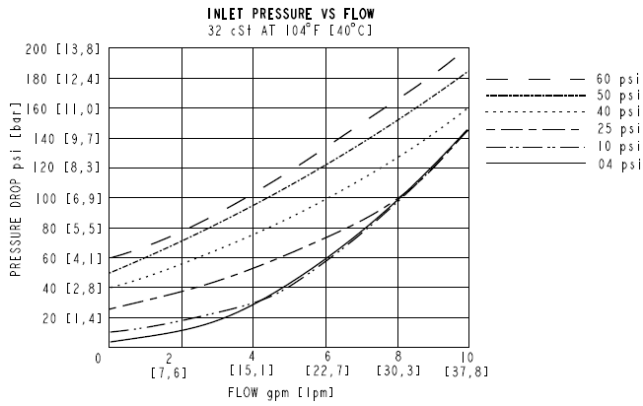

Dimensions

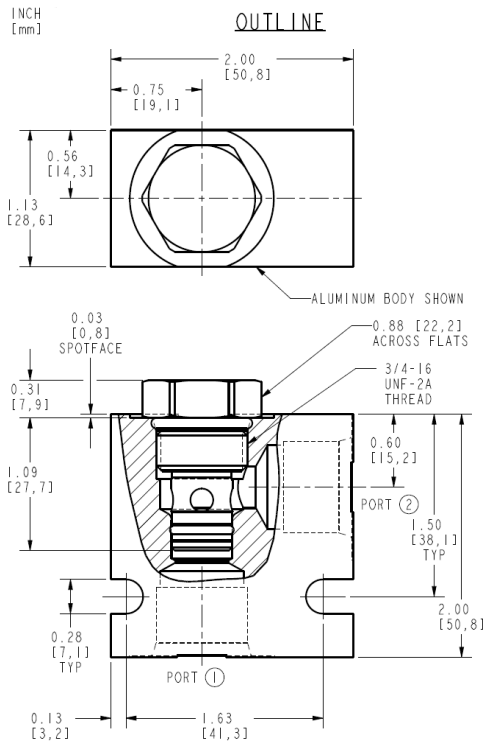

ALL DIMENSIONS ARE FOR REFERENCE ONLY.



Installation Specifications

Cavity	VC08-2
Cartridge installation torque	25.8 to 28.5 N-m (19 to 21 ft-lb)
Maximum allowable torque	54 N-m (40 ft-lb)
Orientation restriction	None

Accessories

Seal kit	SK08-2N-T	- Note: Buna N
	SK08-2V-T	- Note: Fluorocarbon
	SK08-2HV-T	- Note: Fluorocarbon
	SK08-2P-T	- Note: Polyurethane
	SK08-2U-O	- Note: Urethane

Order Code

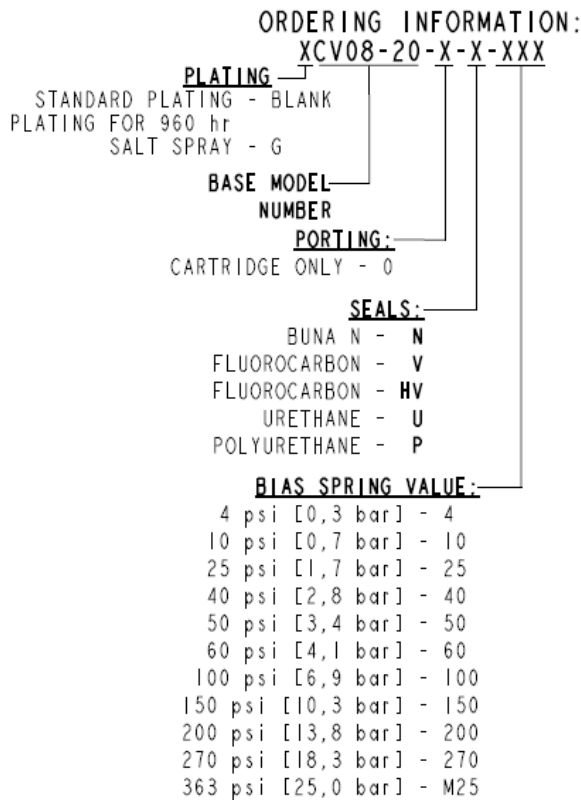

Model Options

CV08-20-H-J-R

H Line Body

CODE	DESCRIPTION
0	No Body
4T	Aluminum SAE 4
6T	Aluminum SAE 6
8T	Aluminum SAE 8
6TD	Ductile Iron SAE 6
8TD	Ductile Iron SAE 8
2B	Aluminum BSPP 1/4" (2)
3B	Aluminum BSPP 3/8" (3)
3BD	Ductile Iron BSPP 3/8" (3)

J Seal



CODE	DESCRIPTION
N	Buna-N
V	Fluorocarbon
P	Polyurethane
U	PPDI Urethane

R Spring

CODE	DESCRIPTION
4	4 psi Bias Spring
10	10 psi Bias Spring
25	25 psi Bias Spring
40	40 psi Bias Spring
50	50 psi Bias Spring
60	60 psi Bias Spring
80	80 psi Bias Spring
100	100 psi Bias Spring
150	150 psi Bias Spring
200	200 psi Bias Spring
270	270 psi Bias Spring
M25	25 bar Bias Spring