



## Overview

### Description

The MR10-47X is a direct acting, manual rotary, spool type, 3 position, 4 way directional control valve with adaptability to a variety of adjustment operators (order separately). It is a screw in cartridge type for use with general purpose hydraulic fluids.

### Operation

Three positions: centered, 45° counterclockwise, and 45° clockwise. In the center position ports 1, 2 and 4 are open while port 3 is closed. In the 45° counterclockwise from center position, ports 1 and 4 are open while ports 2 and 3 are open. In the 45° clockwise from center position, ports 1 and 2 are open while ports 3 and 4 are open. All ports are partially open in transition.

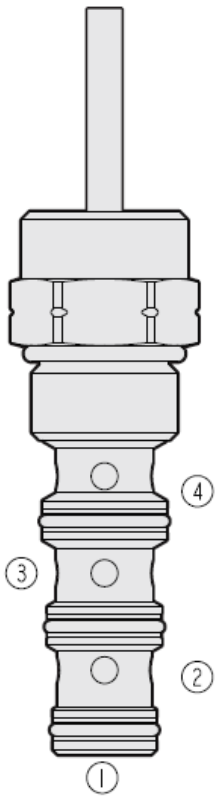

### Symbol

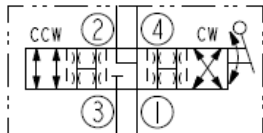

## Ratings

### Pressure Ratings

Pressure rating 241 bar (3500 psi)

### Flow Ratings

Flow rating See chart

Maximum internal leakage 164 ml/min (10 in<sup>3</sup>) - **Note:** At 241 bar (3500 psi)

### Temperature Ratings

Operating fluid temperature	-40 to 100 °C (-40 to 212 °F)	- <b>Note:</b> With buna N seals
	-26 to 204 °C (-15 to 400 °F)	- <b>Note:</b> With fluorocarbon seals
	-54 to 107 °C (-65 to 225 °F)	- <b>Note:</b> With polyurethane seals
Storage temperature	-60 to 71 °C (-76 to 160 °F)	
Ambient temperature	-60 to 90 °C (-76 to 194 °F)	

### Other Ratings

Corrosion protection 960 hr salt spray per ASTM b117 (gmr10-47x)



## Operating Parameters

Fluids	Mineral based or synthetic hydraulic fluid with lubricating properties
Fluid viscosity range	7.4 to 420 cSt
Maximum operating contamination level	20/18/14 per ISO 4406

## Properties

Unit weight	0.17 kg (0.37 lb)
Internal wetted surface area	175 cm <sup>2</sup> (27.2 in <sup>2</sup> )

## Performance

### PERFORMANCE

PRESSURE DROP VS FLOW  
32 cSt AT 104°F [40°C]

- 3 TO 2 & 3 TO 4  
(FOR A, B, C, D, F SPOOLS)
- 3 TO 1  
(FOR A, B, F, G SPOOLS)
- - - 2 TO 1  
(FOR A, B, C, D, F, G SPOOLS)
- 4 TO 1  
(FOR A, B, C, D, G SPOOLS)

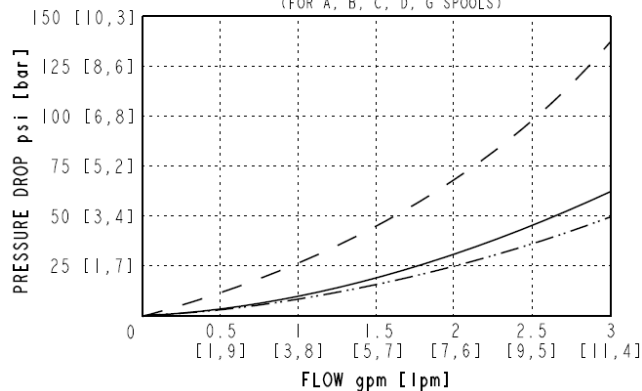

## Dimensions

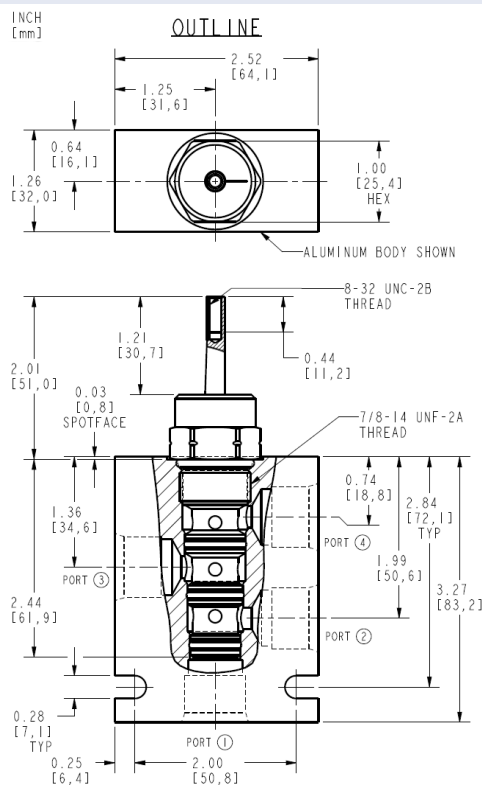

ALL DIMENSIONS ARE FOR REFERENCE ONLY



## Installation Specifications

Cavity	VC10-4
Cartridge installation torque	32.5 to 35.3 N-m (24 to 26 ft-lb)
Orientation restriction	None

## Accessories

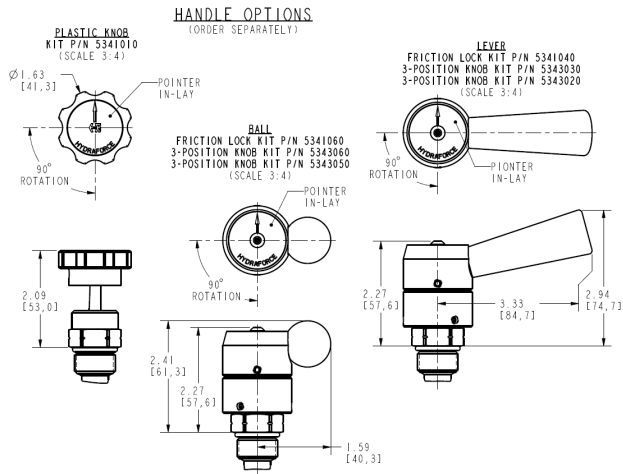

Seal kit	SK10-4N-MMM - <b>Note:</b> BUNA-N
	SK10-4V-MMM - <b>Note:</b> Fluorocarbon
	SK10-4P-MMM - <b>Note:</b> Polyurethane
	SK10-4U-OOO - <b>Note:</b> Urethane
Handle option	Kit: P/N 5341010 - <b>Note:</b> Plastic knob
	Friction lock kit: P/N 5341060 - <b>Note:</b> Ball
	3-position knob kit: P/N 5343060 - <b>Note:</b> Ball
	3-position knob kit: P/N 5343050 - <b>Note:</b> Ball
	Friction lock kit: P/N 5341040 - <b>Note:</b> Lever
	3-position knob kit: P/N 5343030 - <b>Note:</b> Lever
	3-position knob kit: P/N 5343020 - <b>Note:</b> Lever

## Order Code

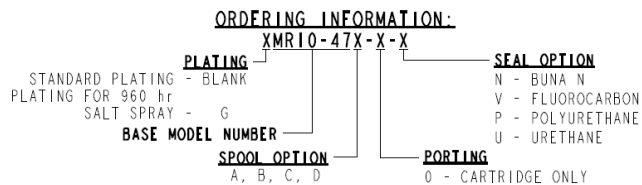

### Model Options

#### MR10-47D-H-J

#### H Line Body

CODE	DESCRIPTION
0	No Body
6T	Aluminum SAE 6
8T	Aluminum SAE 8
6TD	Ductile Iron SAE 6

#### J Seal

CODE	DESCRIPTION
N	Buna-N
V	Fluorocarbon
P	Polyurethane
U	PPDI Urethane